

**STARTER DIMENSION & WEIGHT**

- Net weight : 0.95 kg/set (approximate)
- Gross weight : 1.17kg/set (approximate)

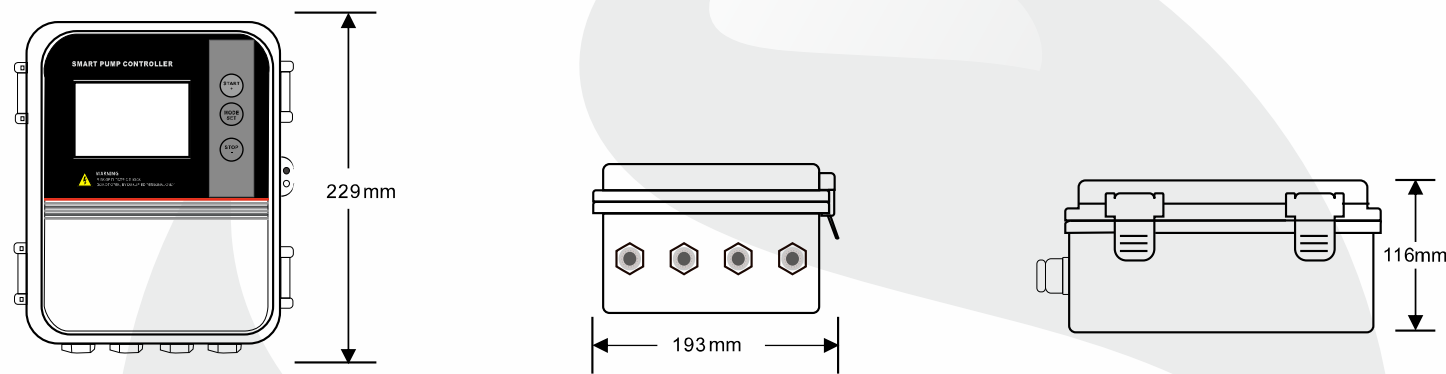

**CIRCUIT DIAGRAM**

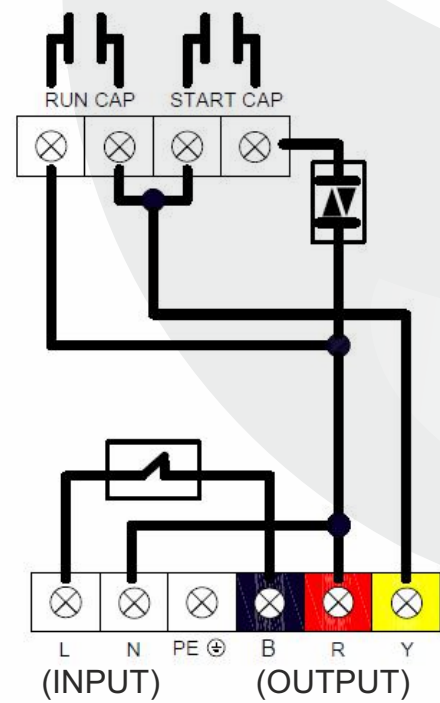

India : Toll Free No. 1800 103 5555

Other Countries : +91-7292 410500

**SHAKTI PUMPS (INDIA) LIMITED**

Corporate Office : Plot No. C-04, Silver Spring, Phase-2, Business Park, Indore-452020. (M.P.) INDIA.  
 Tel.: +91 731 3635000  
 Regd. Office / Factory Add. : Plot No. 401, 402 & 413, Industrial Area, Sector - 3, Pithampur-454774, Dist. Dhar (M.P.) INDIA. Tel.: +91 7292 410500

Authorised Dealer / Distributor :

19 Mar./2026/ R6 | Feb./2025-26/L3/ | VC: | SAP : 2000024421



TAKING 'MAKE IN INDIA' FORWARD.

**SHAKTI SMART CONTROLLER**  
For Single Phase - 50Hz & 60Hz



**SHAKTI**

THE POWER OF INNOVATION, EFFICIENCY & TECHNOLOGY.

**Best Suitable Application**





## INTRODUCTION

Shakti Smart Controller is a smart, reliable, and easy-to-use device designed to control and protect single-phase water pumps.

It is specially made for submersible pumps that use both start capacitor and run capacitor. This controller helps increase pump life, reduce damage, and ensure safe operation.

## APPLICATION

- Deep well pumps
- Submersible pumps
- Sewage pumps
- Self-priming pumps
- Centrifugal pumps
- Pipeline pumps

## CONTROL CHARACTERISTICS

Shakti Smart Controller can be used in:

- Water transfer from underground tank to overhead tank (with float switch)
- Sewage and drainage systems (with float switch)
- Timer-based pump operation

## TECHNICAL DATA

- **Input Voltage:** AC 230V, Single Phase
- **Frequency:** 50Hz / 60Hz
- **Output Power Range:** 0.5 HP to 3 HP
- **Start Type:** DOL (Direct On Line)
- **Pump Control:** Single pump only
- **Working Temperature:** 25°C to 55°C
- **Protection Class:** IP65 (Dustproof & Waterproof)
- **Mounting Type:** Wall mounting



## Supported External Devices:

- Float switch (ON/OFF signal)
- Pressure switch (ON/OFF signal)
- Liquid level probe

## FEATURES

- Easy installation and wiring
- Simple push-button calibration
- Digital LCD display for clear status monitoring
- Shows real-time pump running information
- Displays last 5 fault records
- Displays total (cumulative) pump running time
- Memory function (retains settings after power failure)
- Manual mode with pump stop timer
- Pure cycle timer mode available
- Overflow alarm for sewage applications
- Stable and high-quality electronic components
- Reliable and long service life

## PROTECTION FUNCTION

Shakti Smart Controller protects your pump from:

- **Dry run protection (sensor-free)**

Stops the pump automatically if water is not available.

- **Pump stall protection**

Protects motor if the pump gets jammed.

- **Overload protection**

Protects against excess current.

- **Under-voltage protection**

Stops pump when voltage is too low.

- **Over-voltage protection**

Stops pump when voltage is too high.